

ITEM QTY		DESCRIPTION
1	2	TOP AND BOTTOM BRACE
2	1	SWING FRAME ASSEMBLY
3	2	SIDE BRACE ASSEMBLY
4	1	REAR BRACE PANEL
5	4	#10-32 ACORN NUT, (BLACK NYLON)
6	8	#10-32 X 1/4" PAN HEAD SCREW, (BLACK)
7	50	12-24 X 5/8" PAN HEAD SCREW, (BLACK)
8	2	1/4-20 X 3/4" PHIL FLTHD/NYLON LOCK PELLET
9	2	BLACK NYLON SPACER

CATALOG NO.	DESCRIPTION	RACK UNITS	DIM. "A"	DIM. "B"	DIM. "H"
HPWWMR24	24" WALL MOUNT SWING OUT RACK	12	21.1	18.00	23.764
HPWWMR48	48" WALL MOUNT SWING OUT RACK	26	45.35	42.25	48.014
HPWWMR36	36" WALL MOUNT SWING OUT RACK	21	33.35	30.25	36.014

NOTES:

1. SURFACE FINISH: BLACK POWDER COAT
2. UNIT SHIPS UNASSEMBLED.
3. SPECIFICATIONS SUBJECT TO CHANGE WITHOUT NOTICE.

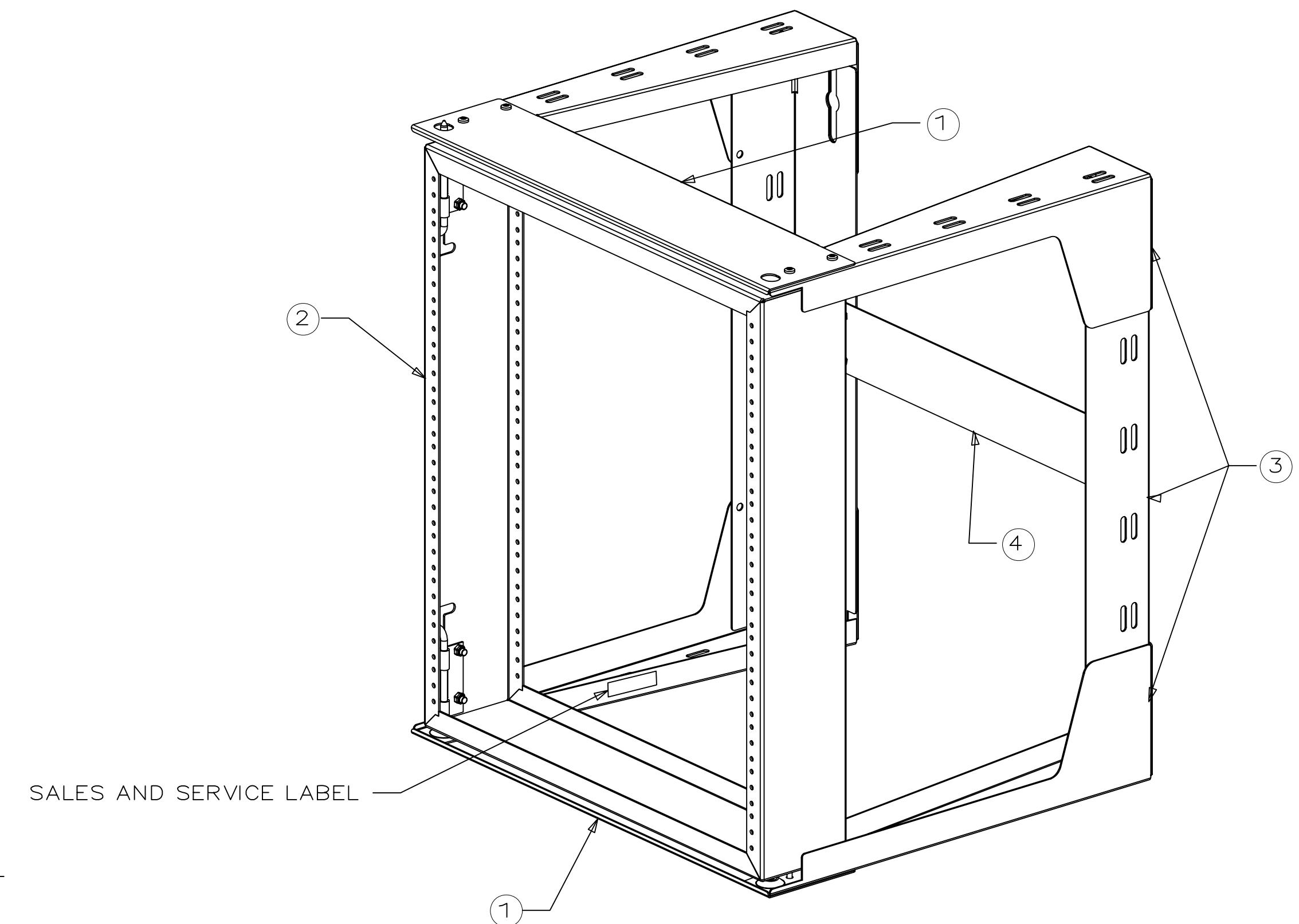
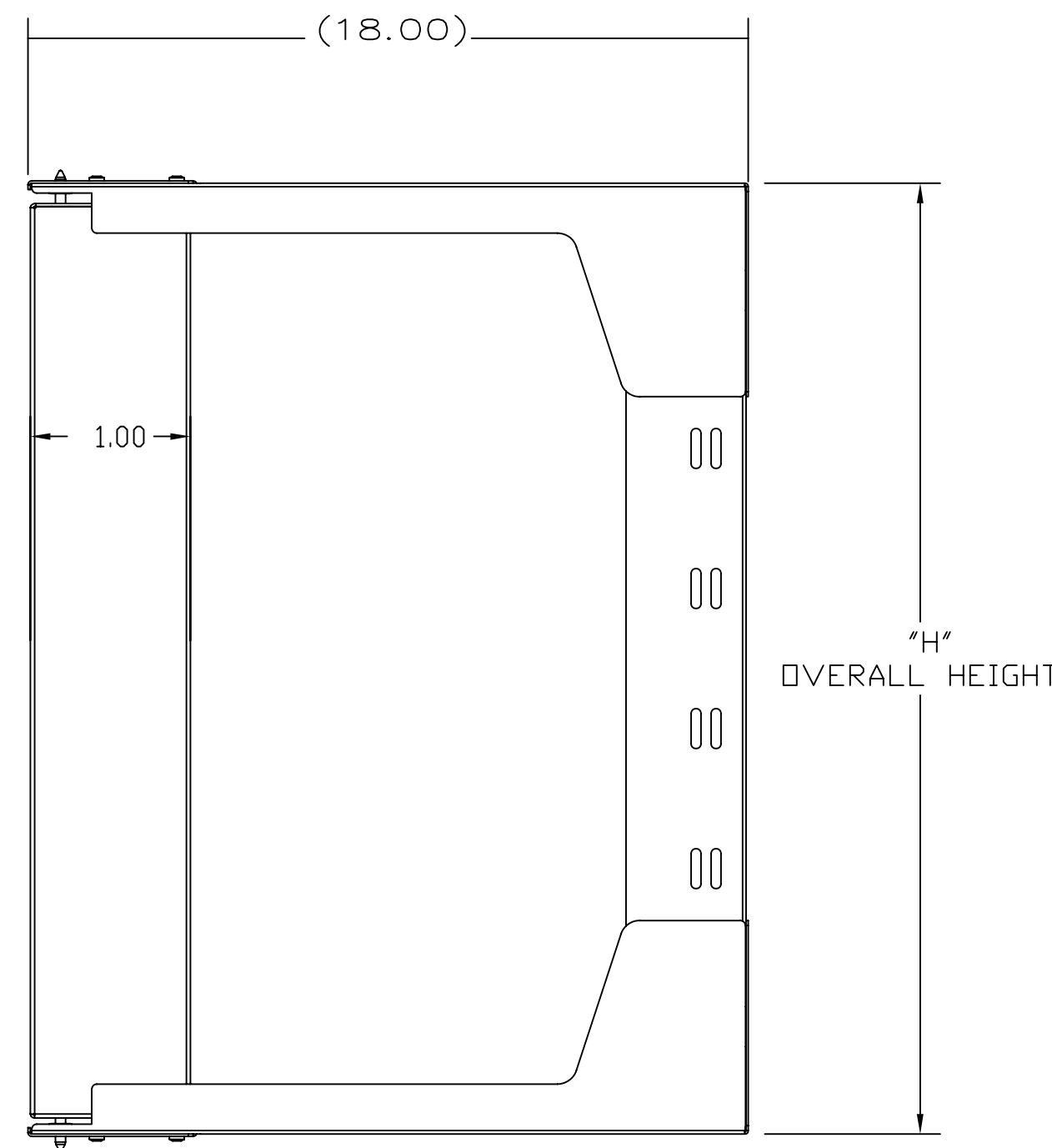
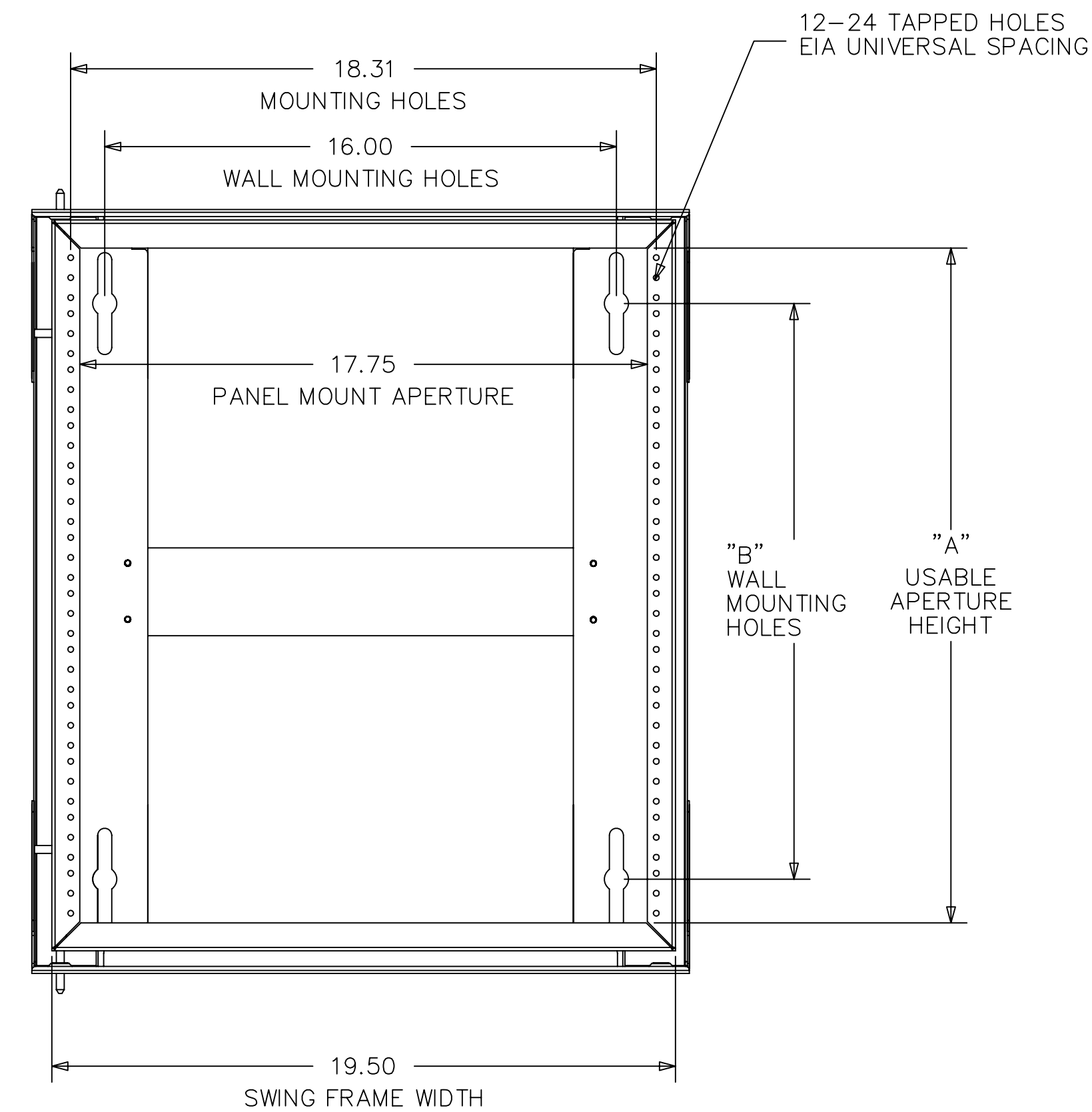
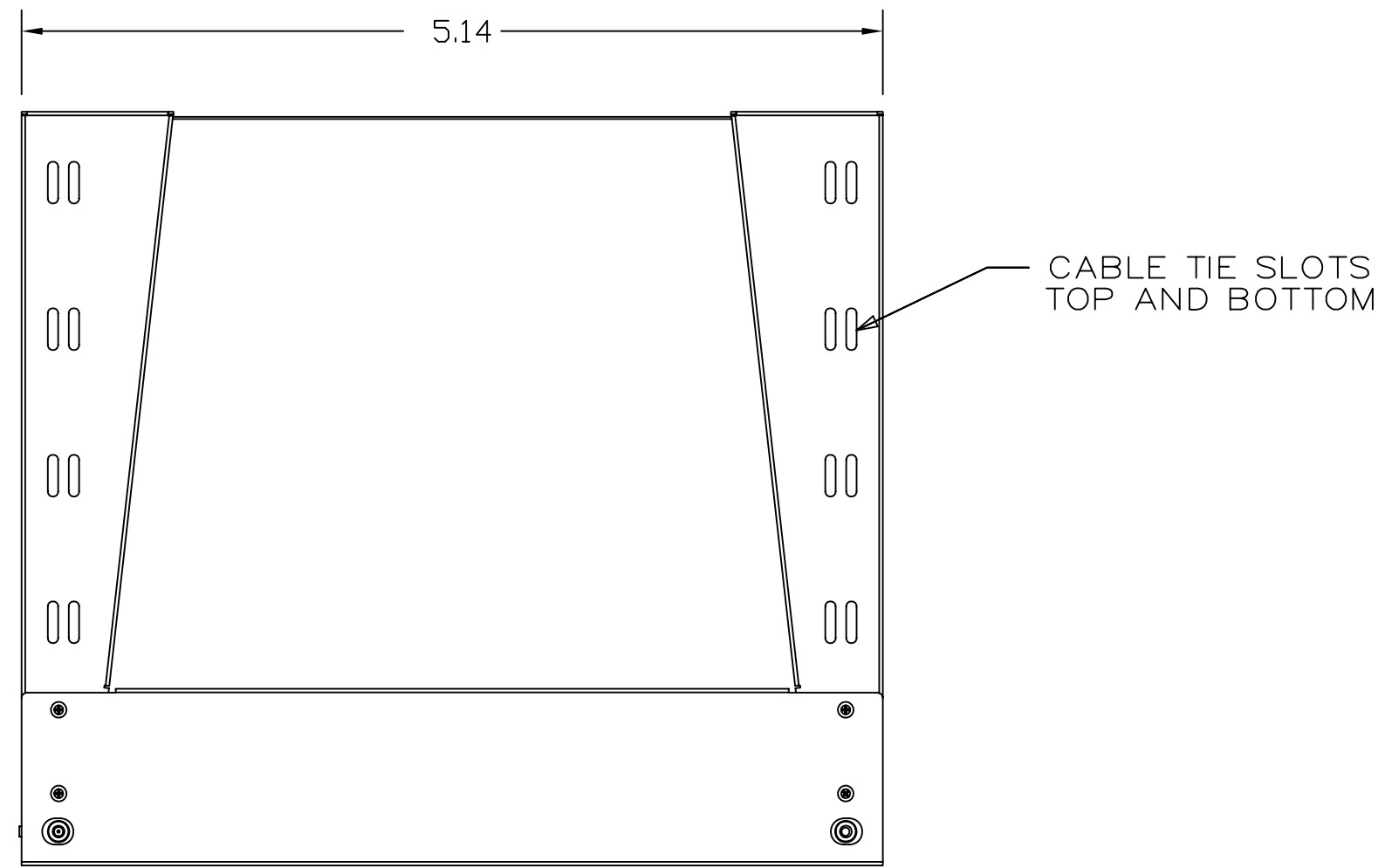

REV.	ECN	DATE	DESCRIPTION	CHG BY	APPD BY
C	6137	06/25/07	REVISED CABLE TIE SLOTS	MMA	MMA

Created on AUTOCAD	DIMENSIONING AND TOLERANCE PER ANSI Y14.5M-1982. UNLESS OTHERWISE SPECIFIED, DIMENSIONS ARE IN INCHES (MM). TOLERANCES .X = ±.03 (.8) .XX = ±.02 (.4) .XXX = ±.010 (.25) ANGLE TOL ±1°	PROJECT REFERENCE:	 Hubbell Premise Wiring HUBBELL INCORPORATED (Delaware) 14 Lord's Hill Road, Stonington, Connecticut 06378
	IN ACCEPTING OUR DRAWINGS, BLUEPRINTS, OR SUPPORTING DOCUMENTATION FOR QUOTATION OR OTHER PURPOSES, YOU AGREE NOT TO DISCLOSE TO OTHERS THE IDEAS, INFORMATION, OR DESIGNS SHOWN HEREIN, AND THAT YOU WILL MAKE NO USE OF SAME WITHOUT PERMISSION	MATERIAL:	
		DRAWN BY: R. REGO	SIZE: D
		CHECKED BY: J. LUTZEN 6/10/99	DRAWING NO. 11051C
		APPROVED BY: J. LUTZEN 6/10/99	REV. C
		SCALE: 1/1	SHEET 1 OF 1